

# Sunfire

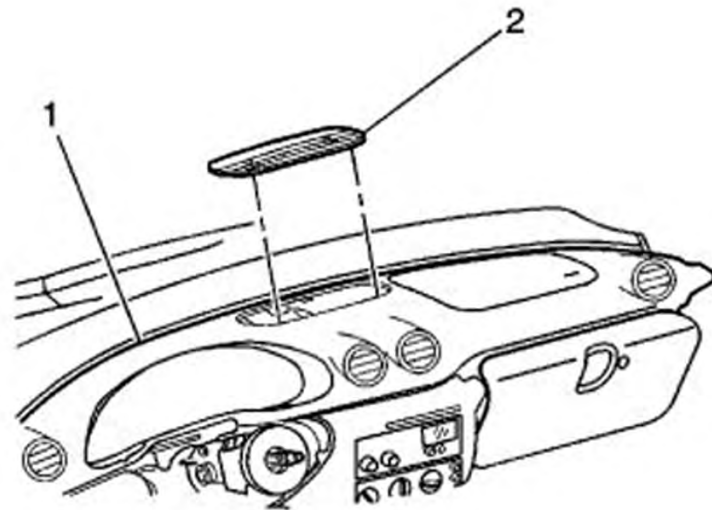

1. Release the defroster grille (2) retainers using a small flat bladed tool.
2. Remove the grille (2) from the instrument panel (I/P) upper trim pad (1).

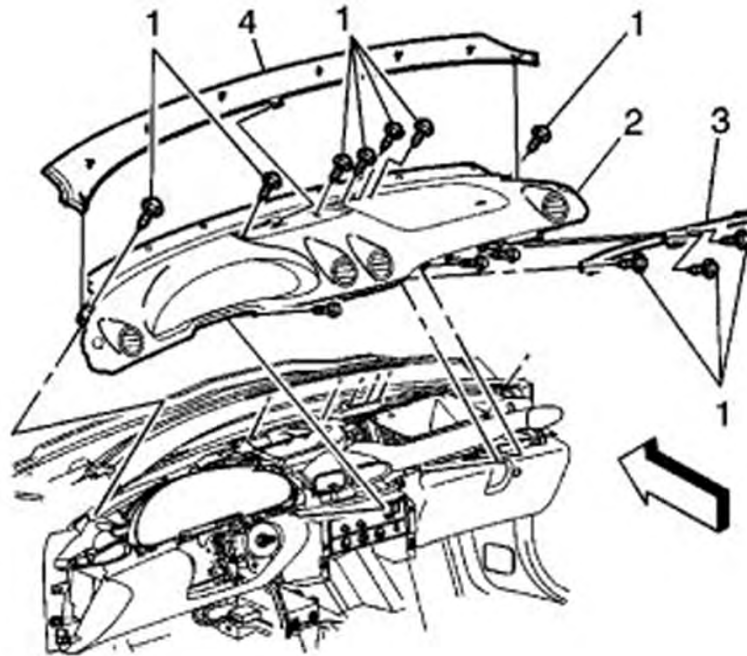

3. The air bag system does not need to be disabled if the passenger air bag is left connected during this process.
4. Remove the I/P upper trim panel (4) by lifting upward to release the retainers.
5. Remove the screws from the I/P outer trim cover
6. Remove the I/P outer trim covers.

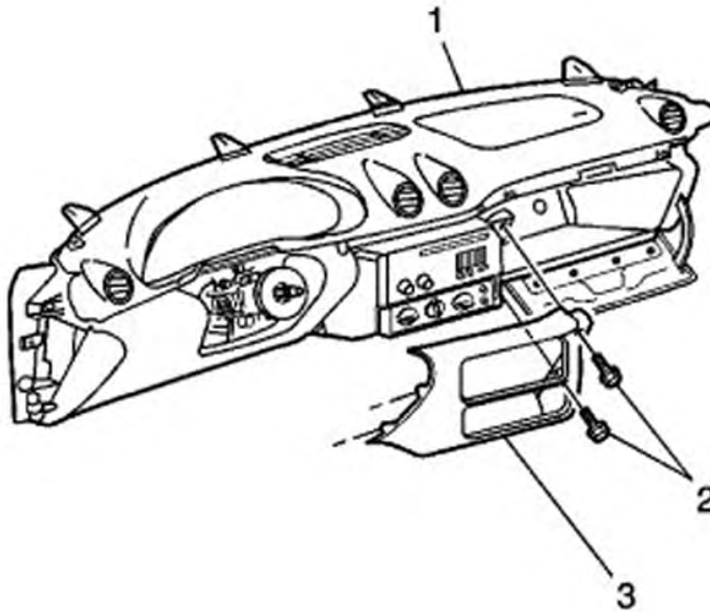

7. Remove the I/P accessory trim plate (3). Open the I/P compartment door in order to access the screws (2).
8. Remove the screws (2) from the I/P accessory trim plate (3).
9. Pull the I/P trim plate (3) rearward to disengage the retainers.
10. Remove the I/P trim plate from the I/P carrier.

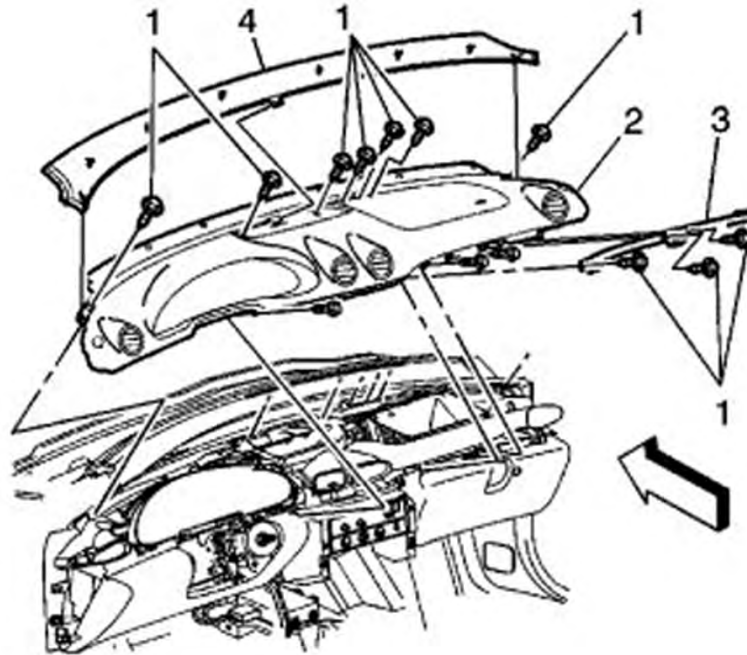

11. Remove the screws (1) from the right I/P trim panel.
12. Remove the right I/P trim panel (3).
13. Remove the screws (1) attaching the I/P trim pad (2).
14. Remove the I/P pad (2) from the I/P carrier.