

## Trailblazer, Envoy, Rainier

1. Tilt the steering wheel to the full down position
2. Remove or lower the left closeout/insulator panel, see pic below:

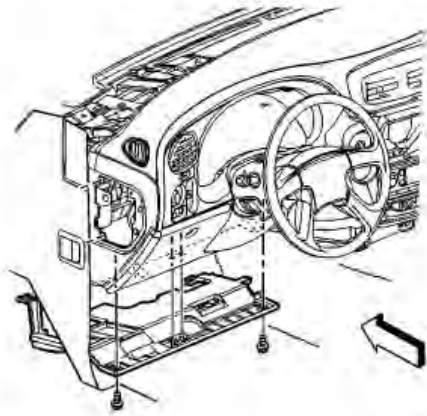

3. Remove the 4 screws from the knee bolster trim panel, see pic below:

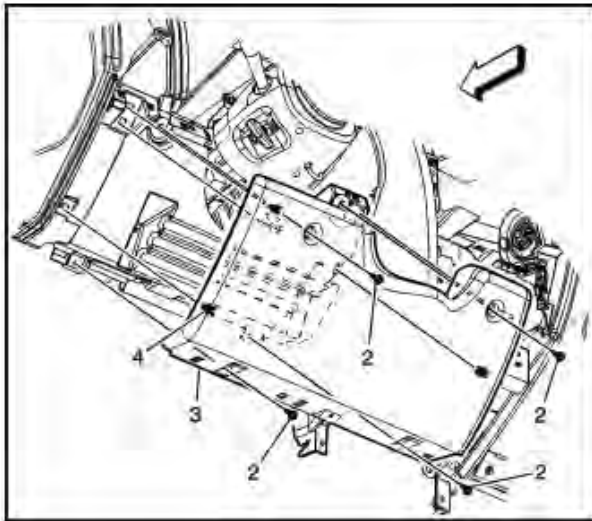

4. Remove the 6 screws retaining the bezel to the instrument panel (Chevrolet pic below).

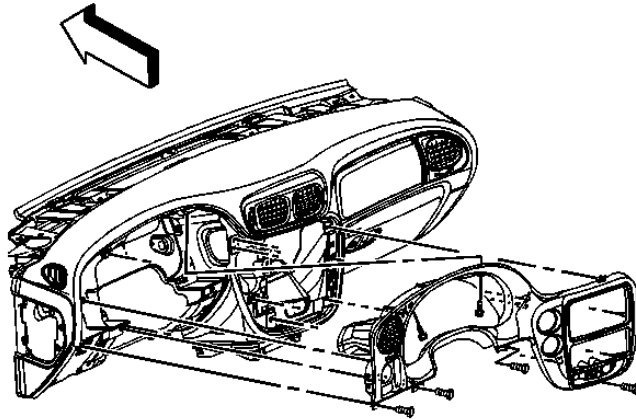

GMC and Buick version below (4 screws):

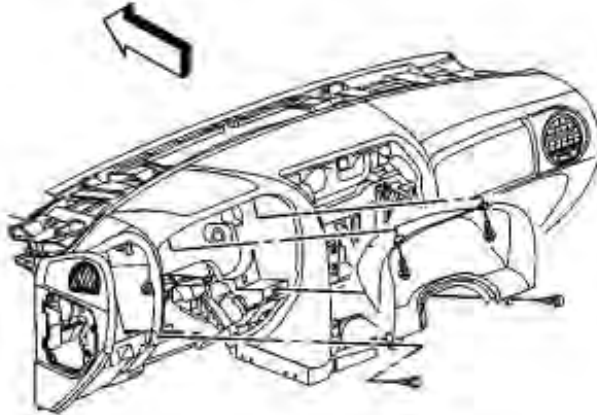

5. Remove the bezel from the instrument panel. (Chevrolet: by tilting it towards the passenger side out of your way, it's not necessary to remove the 4x4 or wiper switch.)
6. After moving the trim plate bezel to the right, simply remove the four 1/4" screws holding the instrument cluster in place. Pull the cluster out and unplug the single wiring harness connection in the back.

